

Pilgrim's Coupling Hole Alignment Tool (CHAT)

The Coupling Hole Alignment Tool (CHAT) is a further development from the Pilgrim product portfolio. Designed in response to OEM maintenance and end user requirements. It achieves coupling hole alignment quickly and to a tolerance that permits effective bolt installation or removal.

The CHAT hydraulically expanding tool is based upon the same principle as the Radial Fit Bolt saving time and therefore reduces cost during the alignment and closure of shaft couplings. Depending upon coupling size, each CHAT package consists of between 3 and 4 tool assemblies. The tools are inserted into equispaced flange holes and are simultaneously pressurised to align the coupling holes. The coupling faces are then closed using the tools in preparation for installation of the coupling bolts.

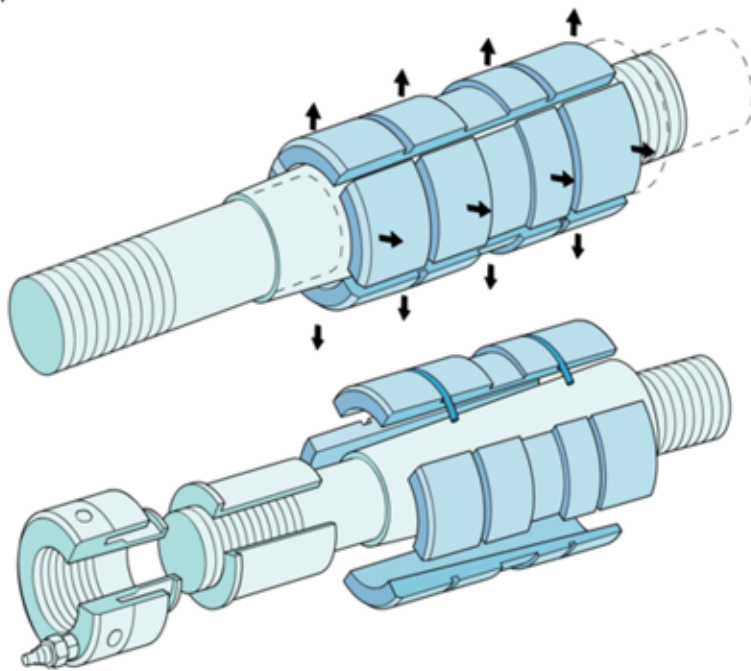

Designed and manufactured specifically to each coupling

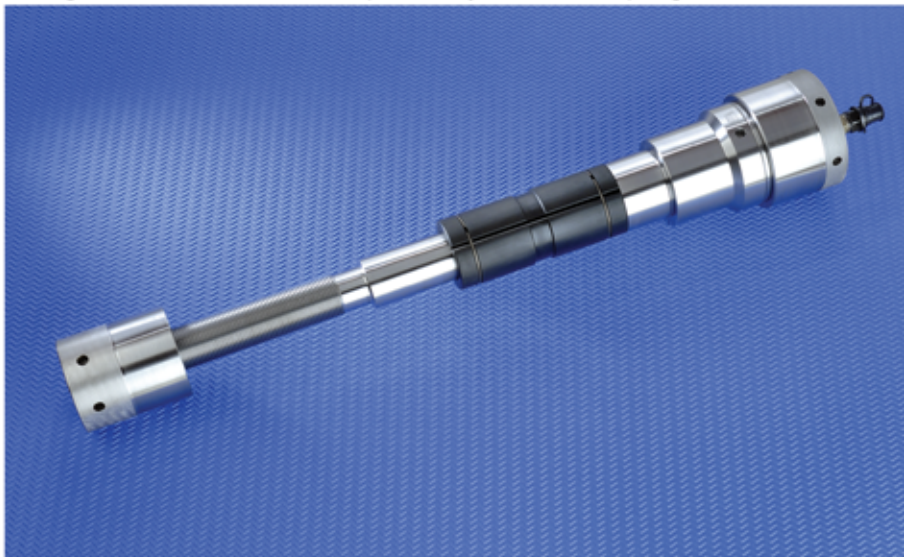

PIL_PRO_008_0719_EN

Typical Applications

- steam Turbine Couplings LP to IP, IP to HP & HP to Gen
- Gas Turbine Couplings LP to IP, IP to HP & HP to Gen

Benefits

- Saves time
- Reduces cost
- Aligns and closes couplings
- Accurate and reliable
- Quick and efficient
- Versatile
- Powerful and safe
- Easy to handle and operate
- Suitable for spigotted or plain Coupling

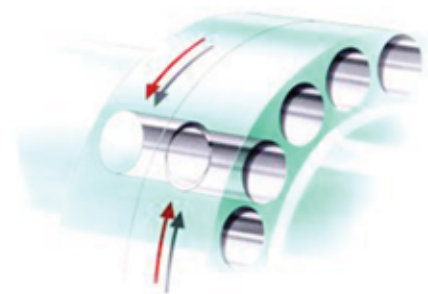

Contact Us:

Telephone: +44 161 785 7700

e-mail: sales@pilgrim-international.co.uk